



# LONG BEACH UNIFIED SCHOOL DISTRICT SCIENCE FAIR INFORMATION

For Parents and Students  
Secondary Level

Revised October 2009



## THE SCIENTIFIC PROCESS

- I. **STATE THE PROBLEM** in the form of a **question**. Choose a subject in which you are interested.
- II. **PRELIMINARY RESEARCH**  
Research, read, watch science videos, use the internet, and contact resource people who may help. Incorporate prior knowledge.
- III. **FORM A HYPOTHESIS**  
Make an educated guess, based on your preliminary research, which answers the problem.
- IV. **EXPERIMENTATION**
  - A. **Materials:** Plan, collect, and list the materials needed for your experiment. It is best to borrow, make or use inexpensive materials.
  - B. **Procedure:** Plan the steps of your experiment carefully. Conduct your experiment.
  - C. **Observe and record data:** Observe and record what happens during your experiment.
  - D. **Results:** Summarize findings in the form of data tables, graphs, and drawings. Write an analysis of your findings.
- V. **CONCLUSION**  
Write one to three sentences to support or refute your hypothesis.
- VI. **APPLICATION**  
Explain how what you learned from your experiment is applied in the real world.

## THE ENGINEERING DESIGN PROCESS

- I. **ASK** a question or identify a problem you would like to solve.
- II. **BRAINSTORM** possible solutions.  
Evaluate positive and negative points of each solution. Choose the best idea.
- III. **PLAN:** Create a plan that includes labeled diagrams and a list of materials needed.
- IV. **CREATE & TEST:** Collect your materials, build your invention according to your plan. Test to see if it works.
- V. **IMPROVE:** Based on results from testing your first design, find where you can improve your design. Re-test after you have made adjustments.

## SUPPLIES & MATERIALS NEEDED

- Display Board (not white)
- Report cover with 3-hole fasteners
- Glue
- Colored construction paper
- Experiment materials
- Display items

### **Dear Parent(s) or Guardian:**

The science fair project is an activity that draws upon basic and advanced skills that have been taught and emphasized in your child's science program. Students generate a science fair project and apply the scientific method to solve the problem. Your help may be needed throughout your student's project. For example, your child may ask for your assistance in the following ways:

- Conducting research via libraries or internet.
- Typing presentation materials for display.
- Retrieving necessary materials needed for their experiment.

Please go over the information presented in this student information folder and discuss it with your child. Some of the details not in the folder have been or will be discussed in class. Contact me at school with any concerns or questions.

Sincerely,

**Your Child's Science Teacher**

\* \* \* \* \*

*I have read the Science Fair Parent Letter.*

Date: \_\_\_\_\_

Parent Signature: \_\_\_\_\_

Student Name: \_\_\_\_\_

(Please Print)

## SCIENCE FAIR MATERIALS SOURCES

**ALIN PARTY COMPANY**  
4139 Woodruff Ave., Lakewood  
(562) 420-2489

**CM SCHOOL SUPPLIES**  
5440 E. Del Amo, Long Beach  
(562) 429-2425

**HOME DEPOT**  
2450 Cherry Ave., Signal Hill  
(562) 595-9200  
751 Spring St., Signal Hill  
(562) 426-4667  
5000 Hardwick St., Lakewood  
(562) 529-3500  
[www.homedepot.com](http://www.homedepot.com)

**LOWE'S**  
7300 E. Carson St., Long Beach  
(562) 421-9996  
2840 Bellflower Blvd., Long Beach  
(562) 496-8120  
[www.lowes.com](http://www.lowes.com)

**LYON'S ART SUPPLY**  
420 E. 4<sup>th</sup> Street  
Long Beach, CA  
(562) 435-5383

**MICHAEL'S CRAFTS**  
4000 Hardwick St., Lakewood  
(562) 633-1913  
7320 Carson St., Long Beach  
(562) 377-0669

**OFFICE DEPOT**  
2301 E. Willow, Signal Hill  
(562) 427-6333

**RADIO SHACK**  
For a location near you, call  
(800) 843-7422

**STAPLES**  
3515 Atlantic Avenue, Long Beach  
(562) 427-6477  
4600 Pacific Coast Highway, LB  
(562) 597-1922  
7400 E. Carson St., Long Beach  
(562) 377-0403  
[www.staples.com](http://www.staples.com)  
1-800-378-3-2753

## SOURCES FOR RESEARCH

- Botanical Gardens
- Industries
- Nature Centers
- Public Libraries
- Marine Reserves
- Animal Hospitals
- Natural Museums
- Telephone Book
- Water Department
- Parks
- Airports
- Commercial Nurseries
- Zoos, Aquariums, Wildlife Rescue Centers
- Colleges and Universities including libraries
- Local hospitals including research facilities and libraries
- Medical, Dental, or Veterinary Offices
- Scientific Websites
- Government Agencies (*Examples: Government Printing Office, Department of Fish and Game*)

## GRADE LEVEL PROJECT FOCUS

Students are encouraged to reflect the district standards and grade level objectives in their science projects. To meet this, students may choose projects which focus as below. See on-line rubrics for details.

### 6<sup>th</sup> - 12<sup>th</sup> Grade:

- Create an **Invention** to solve a real life problem using the Engineering Design Process.

### 6<sup>th</sup> - 8<sup>th</sup> Grade:

- **Career Shadow**  
Shadow a science mentor
- **Rube Goldberg Device**  
Use energy transfers to design a project

### 6<sup>th</sup> - 12<sup>th</sup> Grade:

- **Experiment** to answer an original question using the Scientific Method

### 7<sup>th</sup> Grade ONLY:

- Design a science or health project using a carefully constructed **Survey** as part of the experimental procedure.

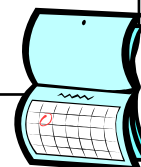

## STUDENT SCIENCE FAIR PROJECT TIMELINE

TASK	Teacher's Date Due	Teacher's Initials	Parent's Initials
1. Choose, and submit for teacher approval, a topic question/problem to investigate			
2. Do preliminary research. Collect and read books for your topic.			
3. Develop a hypothesis (your best guess) based on your preliminary research.			
4. Decide on the procedure that you will use to test your hypothesis.			
5. Make a list of your materials. Gather your materials.			
6. Conduct your experiment or scientific survey, build and test your invention or Rube Goldberg Device, or shadow your science career mentor. Record data.			
7. Organize your data and results.			
8. Write your conclusion based on your results. Write a "real world" application of what you learned.			
9. Write a draft of your science fair report.			
10. Proofread your draft or have someone else proofread it. Type or write a final copy of your report.			
11. Assemble your science fair display board and display items.			
12. Turn in your science fair project (report, display board and display items).			
13. <b>Take your science fair project home.</b>			

**Note:** The student should keep his/her research, update sheets, letters home to parents, and other information this folder. This folder should be kept at home unless otherwise instructed.

# SCIENCE FAIR WRITTEN REPORT

Scientists always report the results of their research and experimentation so that others may benefit from this new knowledge. Some work is reported through published papers and other scientists present their work at conventions, on TV, or through the Internet. Your research will be presented through your written report, a project display, and an oral presentation.

## ABSTRACT

The abstract is a concise, one-half to one page summary or overview of your whole project. Others can read your abstract if they do not have time to read your paper. You must write the abstract after your report is complete.

## TITLE PAGE

Put the project title in the center of the page.

In the lower right corner, have:

**Last Name, First Name**  
**Grade** \_\_\_\_  
**Period** \_\_\_\_  
**Teacher Name**  
**School Name**  
**Date (include year)**

**NOTE:** This same, exact information will also go in the upper right corner of your *report cover*, and on the upper right corner on the *back of the display board*.

## PURPOSE

In one short paragraph, tell why you did your project on the topic you chose.

## ACKNOWLEDGEMENTS

This is a "Thank You" to all the people who helped you with your project. Include family members, teachers, or experts who provided you with assistance or participated in some way in your project.

## TABLE OF CONTENTS

Divide your Table of Contents into sections. Type in the actual page numbers *after* you have finished the final copy of your report.

## PROBLEM

State the problem in the form of a question. (Example: "Can plants grow upside down?") Note: Your page numbering begins here.

## PRELIMINARY RESEARCH

This section includes the history and general background needed by the reader to understand your project. Also include any previous research on your topic. Use notes from books, journals, the Internet, magazines, and interviews to write this section of your report. You will conduct research mainly at city and college libraries. You should interview at least one expert in your field of study. You should keep a log of libraries visited, dates visited, and sources researched.

Information received via the computer must also be documented. The minimum number of typed, double-spaced pages in the research section will be determined by your teacher. Standard-sized letters and margins must be used. Type or write on only one side of the paper and do not use subtitles. The ability to take a large amount of information, organize, summarize, blend it together, and then write it out in a coherent manner is certainly a skill needed during the research phase of the report.

## HYPOTHESIS

This is an educated guess (based on preliminary research) which answers the problem. The hypothesis is a statement that is generally one sentence long. *In the interest of time*, the hypothesis may be formed before the research is completed so that testing the hypothesis (experimentation) may begin. (Example: "Plants grow upside down.")

## EXPERIMENTATION

(This part is not needed for a Survey project. For an Invention project, you may substitute the Engineering Design Process format.)

### MATERIALS

List the materials you used during your experiment. Be very specific. If someone wanted to duplicate your experiment, he or she would have to know exactly what to use and how much is needed.

### **B.** PROCEDURE

The procedure is a detailed list of steps needed to conduct your experiment.

### **C.** RAW DATA

Raw data or observations collected during your experiment should be recorded in a log. This section should be long, detailed, and stated in the present tense. Dates, times, names, responses, measurements, locations, and problems you had need to be recorded. The raw data must be submitted in its original form in a separate data folder. Check with your teacher about the number of trials you should perform. Diagrams and/or photographs are encouraged in this section.

### **D.** RESULTS

This section is a summary of your raw data. The data should be compiled and presented into colorful readable data tables and/or graphs since some data are measurable. Graphing is a means of taking large amounts of data and summarizing the data in a visual manner. All data tables and graphs must be labeled and titled. In addition, write your results in essay form. Summarize all data including the qualitative observations

which could not be put in a data table or graph. Analyze why you think you got the results you did. Discuss any errors that may have occurred and how they affected your results.

## CONCLUSION

State whether your hypothesis is valid or invalid. State your final conclusion. A conclusion is a one-to-three sentence statement. This statement should not add to or take away from the problem or hypothesis.

## APPLICATION

Explain how your project findings apply to you personally or to society, in general.

## REFLECTION

Reflect about the benefits to you doing a Science Fair project and how it benefits you.

## SOURCES

List all books, articles, and other communications or sources that you used for writing your preliminary research section. You must have at least five sources; only one may be an encyclopedia. College libraries and public libraries should be used. Interviews with experts in your field of study are encouraged.

### Points to Remember!

1. **Type or write on one side of the paper only.**
2. **Center the page numbers of your report at the bottom of each page.**
3. **Have someone proofread your report before you make the final copy.**
4. **Put report in a report cover with 3-hole fasteners.**
5. **Turn in your original report and keep a copy at home in case the original gets lost.**



# DISPLAY INFORMATION

## DISPLAY BOARD MATERIALS

The display board must be sturdy and stand by itself on a table. Foam core-board and cardboard are the best materials.

## COLORS

If you need to paint your display board, enamel paint works best. Do not use water-based paint. Contact paper may also be used. Use contrasting colors on your board as backing and a border for all typed material. Background color may NOT be white without permission.

## LETTERING

Your title and subtitles may be computer-generated or cut from construction paper. Do not freehand the letters. The title letters should be 3 to 4 inches high. The subtitle letters should be 1 to 2 inches high. The subtitles which are mandatory on the display board are: **Problem, Hypothesis, Procedure, Results, Conclusion, and Application**. All items on the display must be glued to the board. Do not use pins, tacks, staples, or tape.

## DRAWINGS, PHOTOS, TABLES, AND GRAPHS

Drawings and photos are most useful on the display. Drawings should be drawn in pencil first and then retraced. Drawings should be in color and outlined in thin black felt tip pen. They may also be scanned from the computer. Tables must be displayed in a clear, organized form. Several tables or graphs may be included on one page, as long as the format is clear and easy to read. Tables and graphs must be used in the results section. Tables and graphs should be computer-generated. All tables and graphs must have explanatory titles. Graph axes must be labeled with a description of what each axis represents and the units being represented.

If you have a camera, you should photograph your experiment's progress. A photo of you with your experimental set up is encouraged. All photos must be titled.

## DISPLAY DIMENSIONS

1. When display board is laid open and flat, it should be 48 inches wide.
2. Side panels should be 12 to 18 inches.
3. Height should be no more than 48 inches.

✿ If entering the L.A. County Science Fair, see *L.A. County and California State Fairs*.

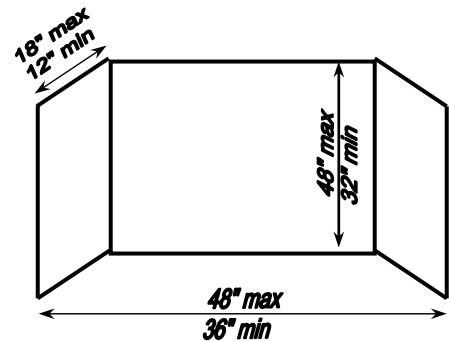

## REPORT POCKET

There must be a "pocket" on the front of the project display to hold your report.

## DISPLAY ITEMS

Something that represents the project should be placed in front of the board. Examples include:

- ◆ equipment or materials used
- ◆ models
- ◆ artistic representations
- ◆ samples or specimens
- ◆ simulated items

There are endless possibilities - be creative!



## SAFETY CONSIDERATIONS

No part of your display may pose a safety hazard. Do not include harmful chemicals, bacterial cultures, sharp objects, or any source of heat or flames. No live or preserved animals are allowed at the LBUSD district-level Science Fair, at the Los Angeles County Fair, or at the California State Fair.

## SCIENCE FAIR PROJECT CHECKLIST ✓

- \_\_\_ There are no tacks, pins, tape, or staples on the display board--- only strong glue. Make sure everything is secure.
- \_\_\_ The student's *name and other required information* are on the back of the display board in the upper right hand corner. (See instructions for Title Page of report.)
- \_\_\_ The report is in a report cover with 3-hole fasteners. The report is in a "pocket" on the front of the display board with the student's *name and other required information* in the upper right hand corner on the outside of the cover.
- \_\_\_ The student has the original report in the report cover and a *copy* at home.
- \_\_\_ Any display items other than the display board and the report are in a paper bag with the student's *name and other required information* on the outside of the bag. Bring a UL approved extension cord for displays requiring electricity.
- \_\_\_ Display items with many pieces (i.e. crystals) are not loose. They are in a display case or other "holder." No harmful materials or substances are part of the project display.
- \_\_\_ The project is completed **before** bringing it to school.